

FOR LOCAL  
BUILDERS



# TECHNICAL HANDBOOK ON **Design, Construction and Renovation of Typhoon-Resilient Low-Income Housing**

Typhoon-resilient houses can have different forms depending on the characteristics of the land and socio-economic conditions of each household. The principles for typhoon resilience recommended in this document, however, should be strictly followed in the housing design process.

*Issued by the Da Nang Department of Foreign Affairs*

*Da Nang, 2017*



FOUNDATION



WALL



ROOF

# INTRODUCTION

Located along the coast, Da Nang is vulnerable to climate-related hazards such as typhoons and floods. It is often affected by typhoons that cause extensive damage to housing, especially those of the poor, near-poor, and low-income population. Such damage has been witnessed repeatedly in the recent past during typhoon Xangsane (2006), Ketsana (2009) and Nari (2013). For the poor, near-poor and low-income population of Da Nang, a house is often the single largest asset and, in many cases, provides space for home-based livelihoods, including storage space for stocks and tools. Housing damage caused by disasters results in loss of life and affects the livelihoods of the population, especially the most vulnerable segment.

Damage to the houses of these vulnerable groups can be significantly reduced by factoring typhoon-resilient considerations into the design, construction, and renovation. Such considerations can be simple, cost-

effective and easily implemented based on available capacity and resources.

Moreover, recognizing the limited engagement of building professionals—engineers and architects—in the design and construction of low-income housing, to strengthen typhoon-resilience should be the responsibility of all stakeholders, especially household residents, local builders, and local officials.

This handbook is targeted at local builders and provides guidance and options for typhoon-resilient features to be incorporated in the housing development process. The accompanying handbooks, with the same name as this document, provide guidance for local officials and low-income households.

FOR LOCAL  
BUILDERS

## CONTENTS

- 5 FOUNDATION
- 8 WALL
- 14 ROOF
- 22 DOORS AND WINDOWS
- 23 DESIGN OPTIONS FOR TYPHOON-RESILIENT HOUSING

### PRODUCED BY

Da Nang Department of Foreign Affairs (DoFA)  
Da Nang Department of Construction (DoC)  
Institute for Social and Environmental Transition (ISET)

1

## ROBUSTNESS

Robustness anticipates the potential breakdown of systems and ensures failure is safe (called *safe failure*). Failures in one system can be compensated in another, thus avoiding severe impacts.

1.1

One room in the house is designed with a reinforced concrete (RC) frame combined with an RC slab to form a safe box where occupants can find refuge in case of a severe typhoon. This room protects occupants even if other parts of the house collapse.

1.2

The room on the second floor serves as shelter for occupants if the first floor is flooded.

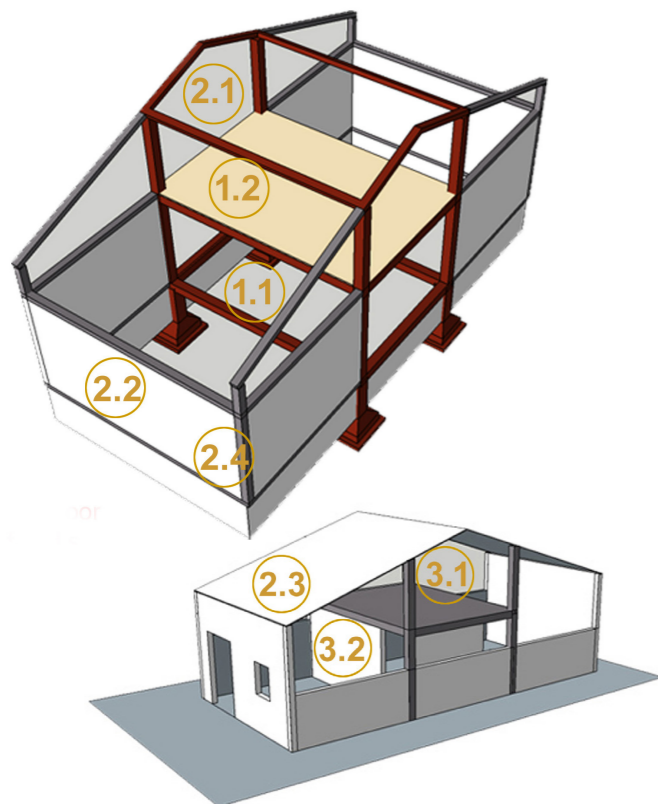

2

## REDUNDANCY

Redundancy refers to the spare capacity to absorb extreme pressures. Interacting components are composed of similar parts that can replace each other if one or many fail.

2.1

The main structure of resilient housing is designed to be stronger than that of traditional housing. All building parts are securely connected such that ring beams, concrete slabs and posts form a solid structure.

2.2

Simple rectangular building forms with gable roofs at a 30-45° angle reduce wind pressure placed on the structure.

2.3

Roof overhangs are protected to reduce wind impacts that damage the roof's structure.

2.4

The reinforced concrete posts and brick walls are securely connected by steel bars with a diameter of 8 millimeters (mm).

3

## FLEXIBILITY

Flexibility refers to viable changes in response to varying circumstances. Assets and functions are distributed so they are not all affected by a given event at once, and provide multiple ways of meeting a need.

3.1

The function of each room is flexible. For example, the room on the second floor of the safe box can be used as a flood shelter, bedroom, study room, altar or storage.

3.2

All materials used for housing construction are locally available and technical designs are simple to apply.

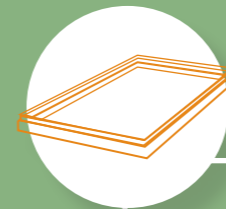

# FOUNDATION

## SITE PREPARATION

- Dismantle old building(s), if any, and reuse materials as much as possible.
- Clean up the site for construction
- Set the location of the house on the land:
  - Determine distance between the house and land boundaries. Position of the house is marked on the ground by setting stakes in the ground (e.g. concrete piles, wood or bamboo stakes).

## FOUNDATION CONSTRUCTION WORK

- To avoid the impacts of rain or underground water on foundation holes, it is essential to have a water pump on site for drainage purposes, if needed.
- After digging foundation holes, pour water into them and ram the holes carefully.
- Pour a concrete layer, 10cm thick, at the bottom of the foundation holes, mixed with stone 4x6cm, mortar M100. Ram the concrete layer carefully and identify the foundation axes.
- Steel work for the foundation is done prepared outside and put into the foundation holes after finishing based on the foundation axes.
- Pour concrete into the hole to make the foundation, ram carefully, let concrete set about 1 day after pouring. After that, the formwork can be removed.
- The steel work for foundation beam is prepared outside. Keep the steel frame within the foundation hole, and ensure the thickness of the concrete layer covering steel bars is  $\geq 2$  cm.
- Pour concrete to make the foundation beam, ram carefully, allow to set for 1 day. After that, the formwork can be removed.

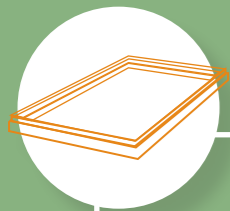

# FOUNDATION

Steel bars for the bottom of pillars' foundation should be perpendicularly placed, diameter  $\geq \Phi 10\text{mm}$ .



The foundation beam is at the same height as the ground floor, continuously going around the house. Minimum steel reinforcement: four steel bars  $\Phi 12\text{ mm}$ , steel wire  $\Phi 6\text{ mm}$ , 15 cm spacing.

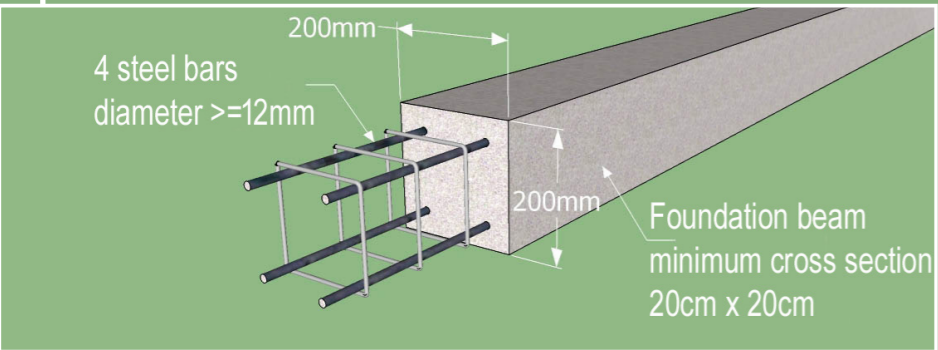
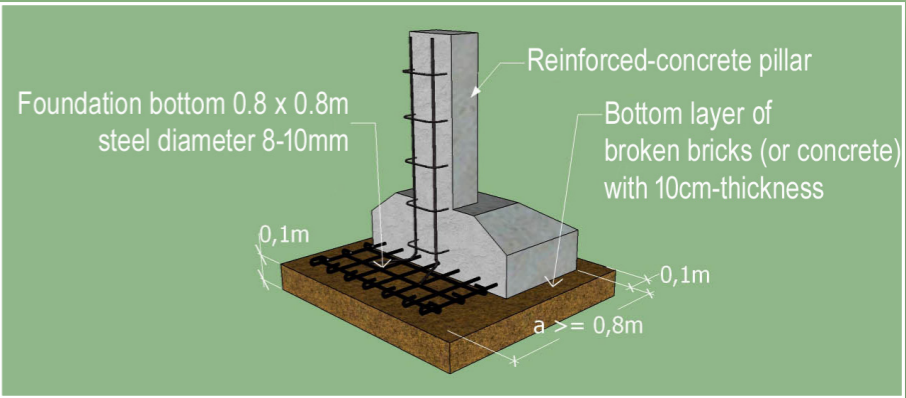

The lower part of pillars, from the foundation bottom to the ground floor, has a minimum cross section area of 20cm x 20cm.

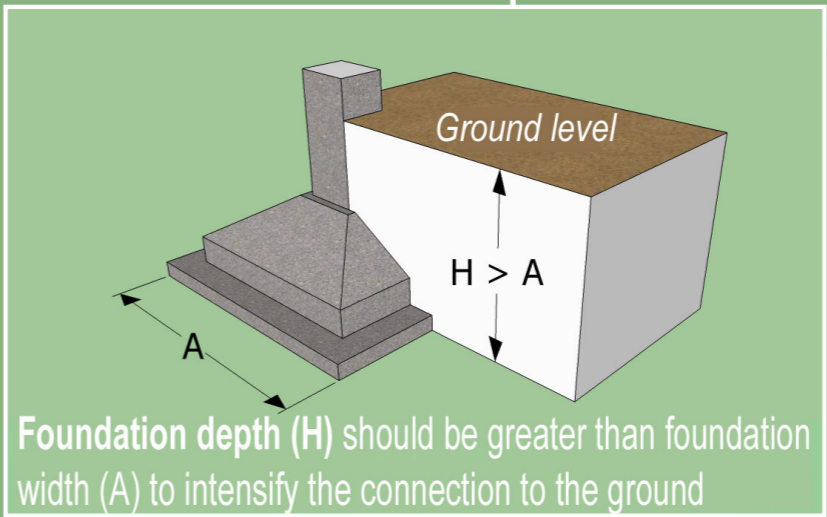

The area of the pillars' bottom should be at least 80 cm x 80 cm, with a 10 cm-thick layer of broken bricks or concrete underneath and extended outside the pillars' bottom, 10 cm per side.

The ground floor should be higher than annual average flood level (if in flooded area).

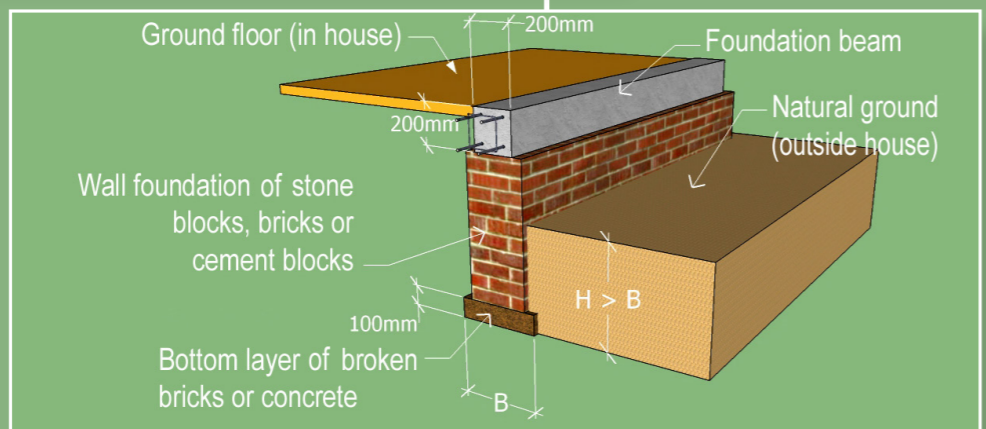

The depth of the foundation should be greater than its width, usually at least 0.5 m (for normal ground). The foundation of the wall is made of stone blocks, cement blocks, or solid bricks, with a width 5 cm greater than the foundation beam on each side.

## FOUNDATION OF STORM SHELTER

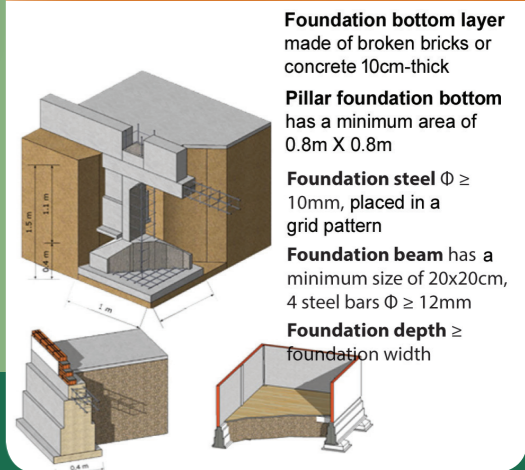

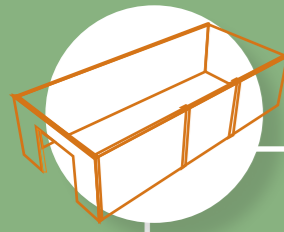

# WALL

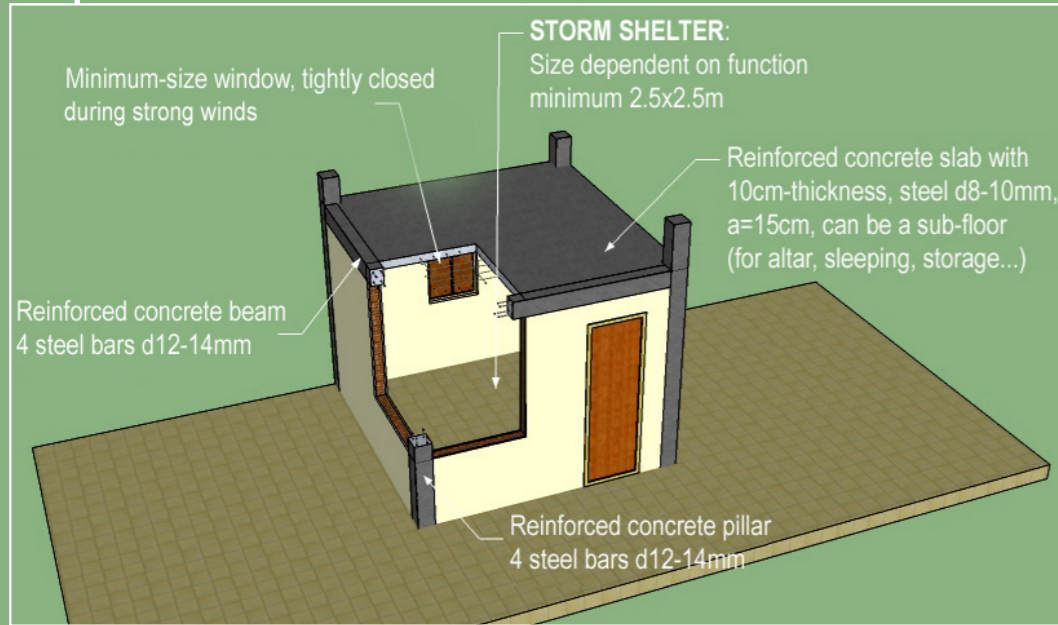

Foundation beam at the top of walls should have the same height as the ceiling. Steel reinforcement: four steel bars  $\Phi 10-12$  mm, steel wire  $\Phi 6$  mm, distance between wires 15 cm.

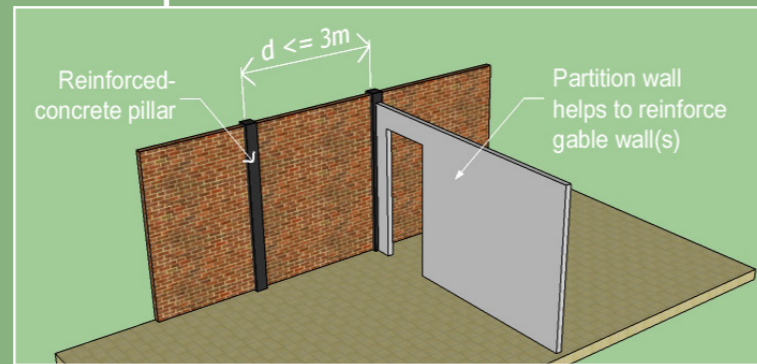

Place steel wire d8mm inside the reinforced concrete pillars when casting them, extending into the wall a minimum of 40 cm from the edge of the column, at spacing  $\leq 0.5$  m.

Walls are usually built with six-hole bricks:

- External (envelop) walls: lay bricks in the horizontal direction, with a thickness of at least 15 cm.
- Internal (partition) walls: can lay bricks in the vertical direction, with a wall thickness of at least 11 cm.

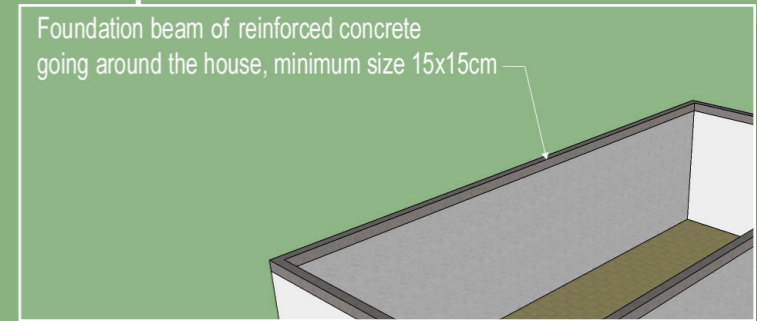

Reinforced concrete pillars are securely connected with the foundation beam and the ring beam at the top of walls.

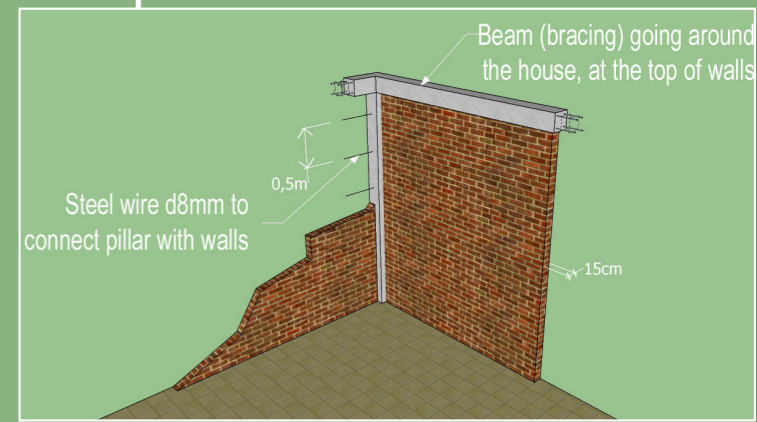

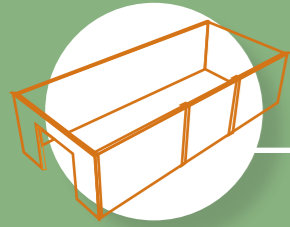

# WALL

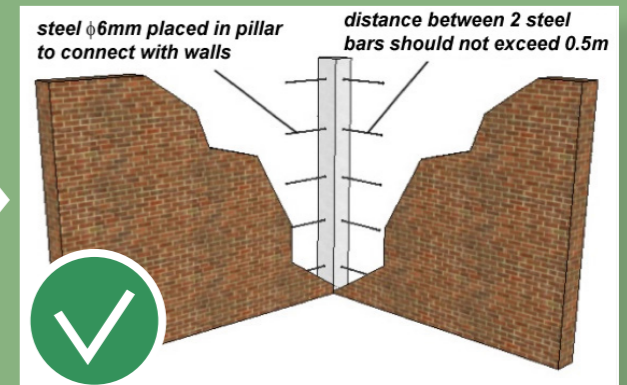
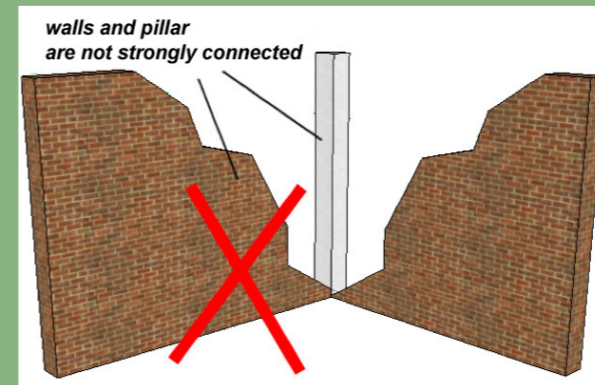
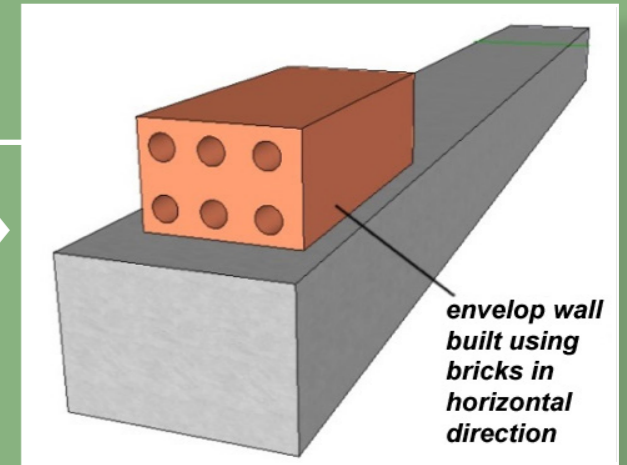
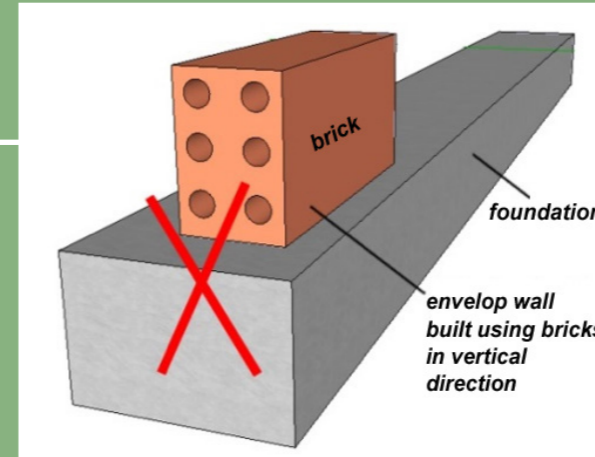
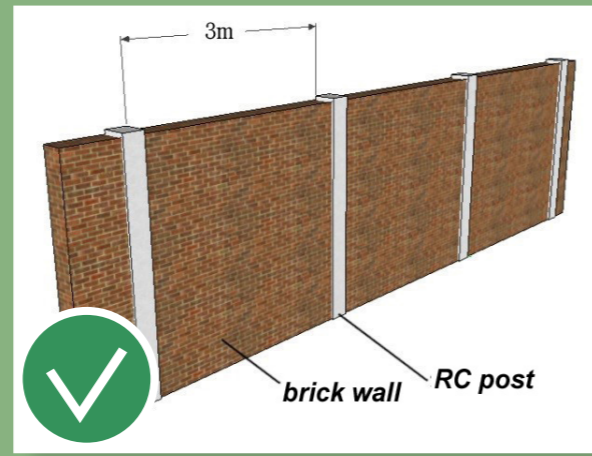
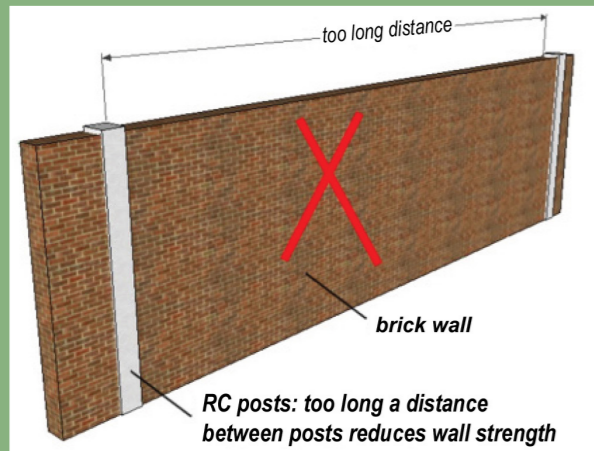
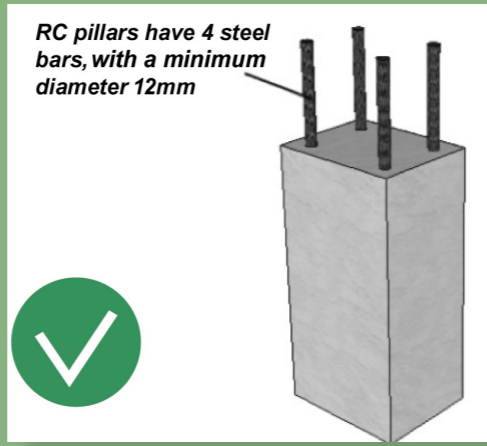
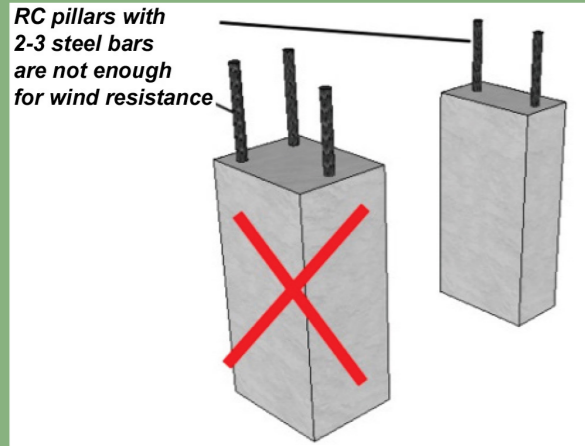

## BEAM & PILLAR FOR STORM SHELTER

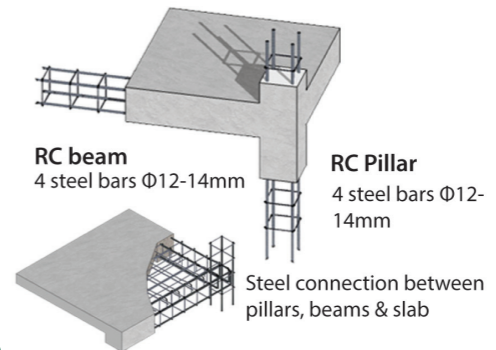

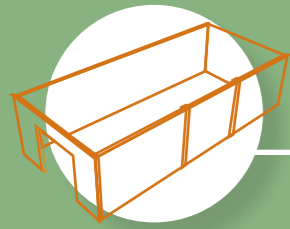

# WALL

## NORM FOR MORTAR

Type of mortar	Mortar strength	Norms for 1 cubic meter (m <sup>3</sup> ) mortar (≈ 20 turtle-formed cart)		
		Cement (kg)	Sand (turtle-formed cart)	Water (liter)
Mortar between bricks	50	213	22 cart	260
	75	296	21 cart	260
Plaster	50	30	21 cart	260
	75	320	21 cart	260
	100	410	20 cart	260

## NORM FOR CONCRETE

Type of concrete	Concrete strength	Norms for 1 cubic meter (m <sup>3</sup> ) mortar (≈ 20 turtle-formed cart)			
		Cement (kg)	Sand (m <sup>3</sup> )	Stone (m <sup>3</sup> )	Water (litre)
Stone 1x2	200	360	9 cart	17 cart	195
Stone 4x6	100	210	10 cart	18 cart	175

Conversion: 1 turtle-formed cart = 0,05m<sup>3</sup>

## WALL CONSTRUCTION WORK

- Bricks must be soaked in water before constructing walls to increase adhesion between brick and mortar.
- After construction, it is vital to cover brick walls and keep them damp them by pouring water on sunny days.
- Mortar line needs to be full inside, not hollow.

## GENERAL PRINCIPLES

**Formwork for pouring concrete items (foundation, pillar, beam, slab) must be:**

- watertight.
- flat, no cracks or warp.
- strong enough and not moved during in the construction process.

**Steel work must:**

- good quality steel, no rust.
- ensure the distance between steel elements is according to the design
- have strong welding and wiring connections.
- use concrete shims when pouring concrete into the steel framework.



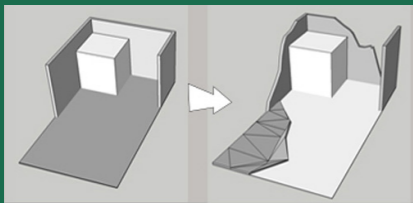

**STORM SHELTER:** a safe place for storm risk reduction, with a foundation, pillars, beams, and slab made from reinforced concrete (RC)

### FOUNDATION ON THE GOOD-CONDITION GROUND

**Foundation bottom layer** made of broken bricks or concrete, 10 cm-thick

**Pillar foundation bottom** has a minimum area of 0.8 x 0.8 m

**Foundation steel**  $\Phi \geq 10$  mm in grid pattern

**Foundation beam** has a minimum size of 20 x 20 cm, 4 steel bars  $\Phi \geq 12$  mm

**Foundation depth**  $\geq$  foundation width

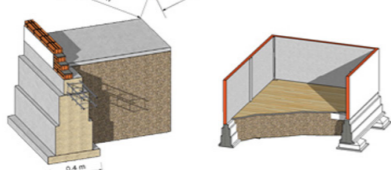
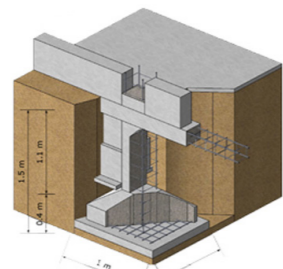

### RC PILLAR & BEAM

**RC beam** 4 steel bars  $\Phi 12-14$  mm

**RC Pillar** 4 steel bars  $\Phi 12-14$  mm

Steel connection between pillars, beams and slab

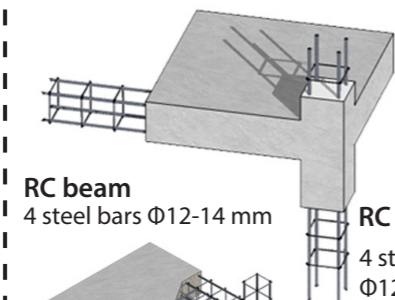

### WALL

**Steel wire  $\Phi 6$  mm** to connect RC pillars with walls, distance between wires  $\leq 0.5$  m

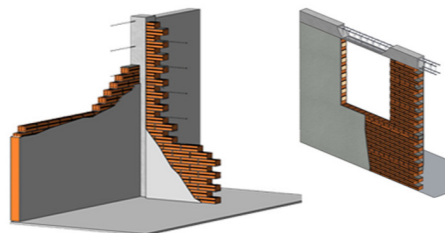

**Six-hole brick wall** with minimum thickness of 15 cm for envelop walls (outside the house), 10 cm for partition walls (inside the house)

### RC SLAB

**RC Slab** Thickness  $\geq 8$  cm, steel  $\Phi \geq 8$  mm, net spacing  $\leq 20$  cm

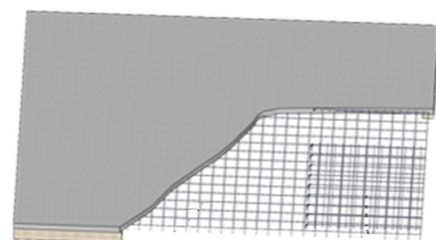

# ROOF

## CLAY TILE ROOF

- Insert mortar, sand at ratio 1:3 to fix clay tiles (3-4 lines) around the roof.
- Build roof edges: ensure mortar-sand ratio is at 1:3.
- Build roof ridges: 1 double-brick line, 1 single-brick line, mortar-sand ratio is at 1:3.
- Use steel wire to attach clay tiles to the roof frames below.

## CORRUGATED STEEL SHEET ROOF

- Attach corrugated iron sheets to roof frames using strong nails or roof-cover screws (plaster cover, iron core). Use iron wires to tie roof covers to roof frames at an interval of 0.5-0.7 m.
- Put consolidation bars (can be made of steel, wood or bamboo) on the roof at an interval of 1.5-2.0 m, at the overlap of two roofs.
- The splint bar can be a steel bar with a diameter of  $>14$ mm, a V-shaped steel bar, or wooden or bamboo bars.



# ROOF

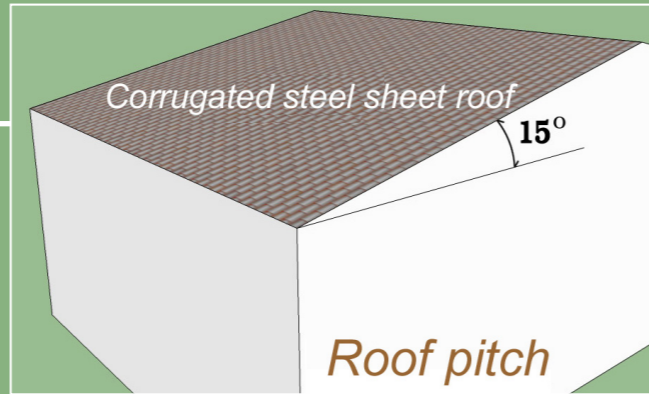
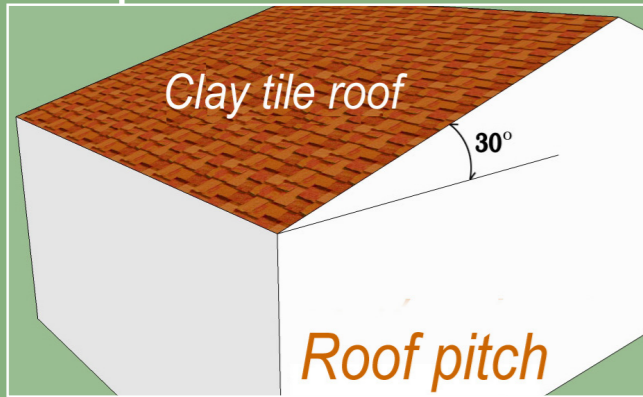
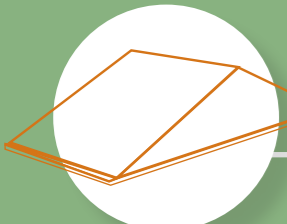

The house should have a ceiling under the roof to reduce blow-off effects caused by storm winds. The distance from the floor to the ceiling should be from 3.6 m to 4 m.

Avoid extending the roof beyond the walls. Cover the roof edges with V-shaped steel sheets (for corrugated steel sheet roof) or with V-shaped tiles (for tile roof).

Do not use fibrocement sheets for roof cover due to its effects on health and safety.

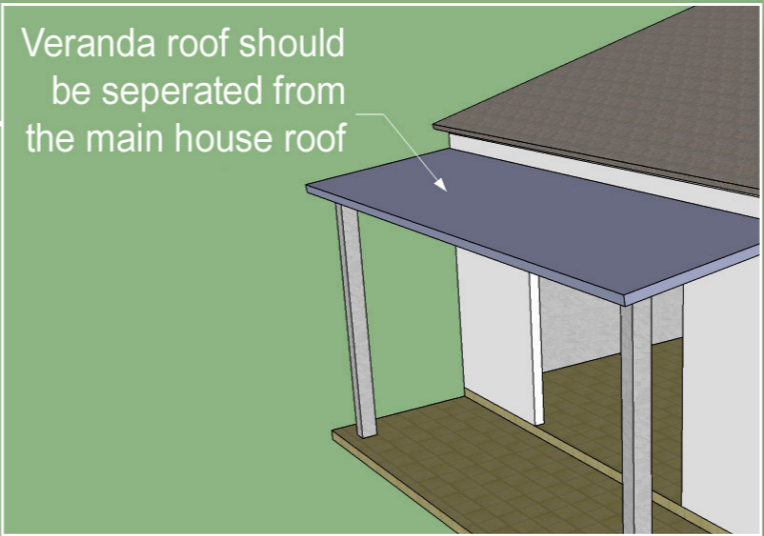
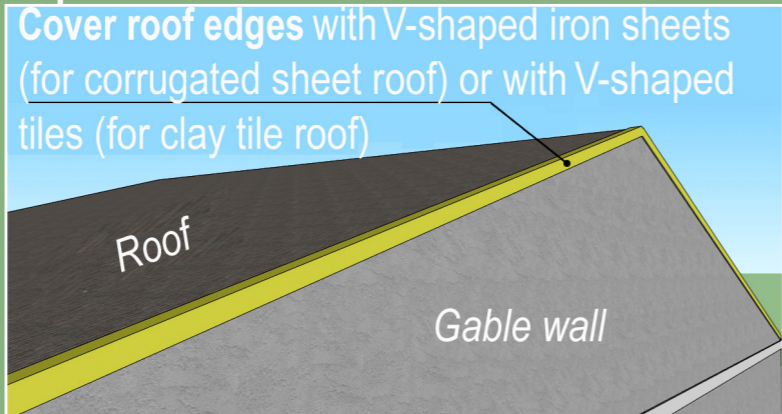

Corrugated steel sheets with a minimum thickness of 0.4 mm. Use bracing bars on roof cover (possibly V-shaped steel bars, wooden or bamboo bars) tightly tied to roof purlins.

Use roof tiles having holes for tightening tiles to roof frames underneath. Tighten by plastic wire at a distance of every two tiles.

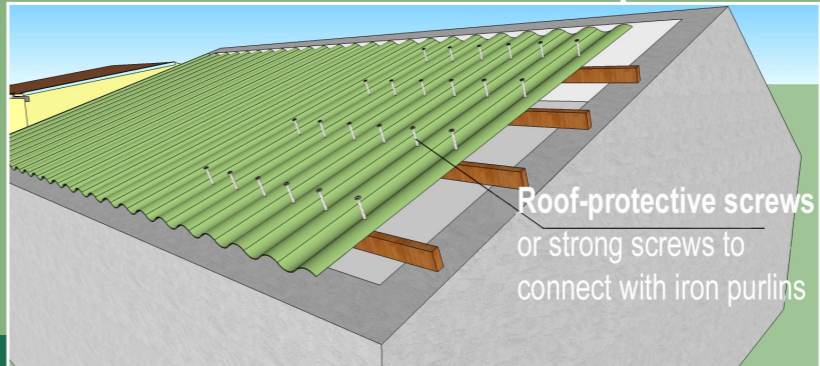
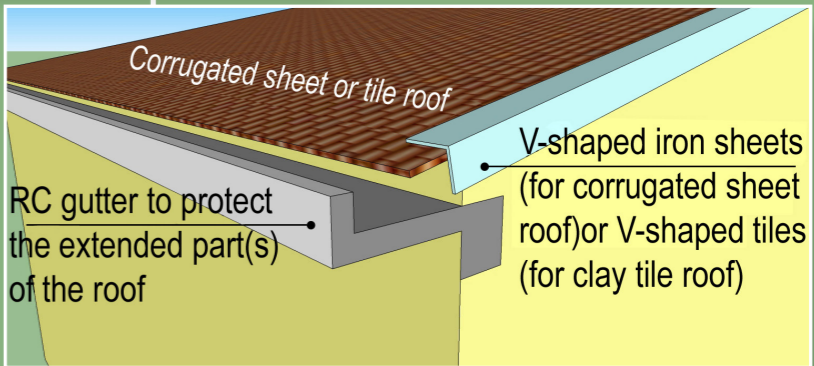

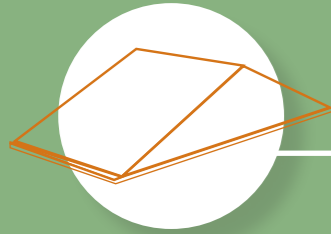

# ROOF

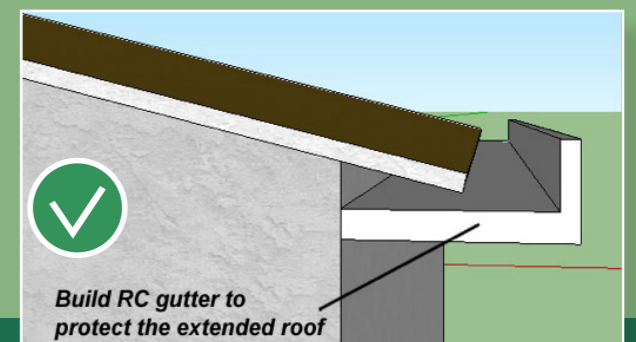
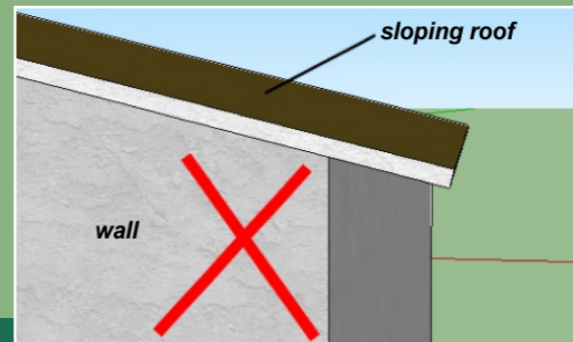
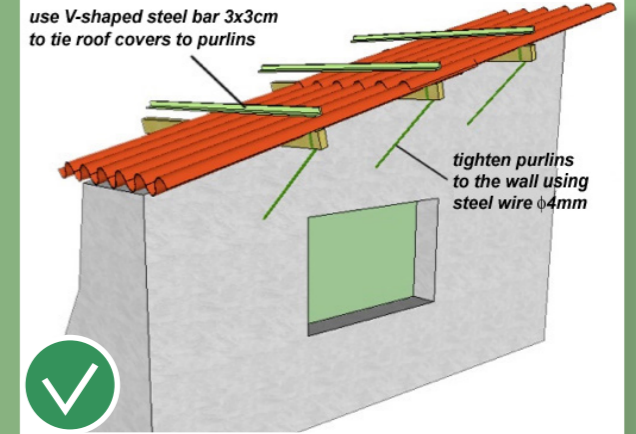
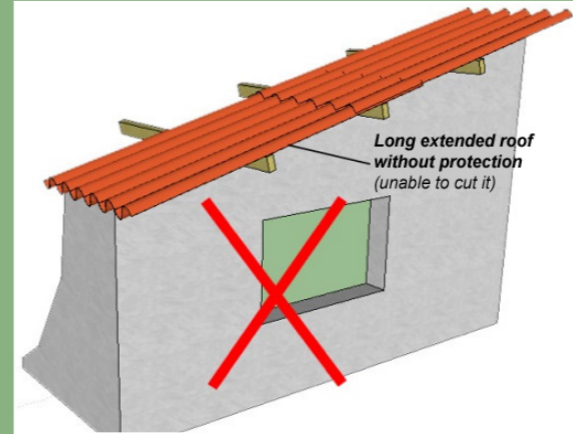
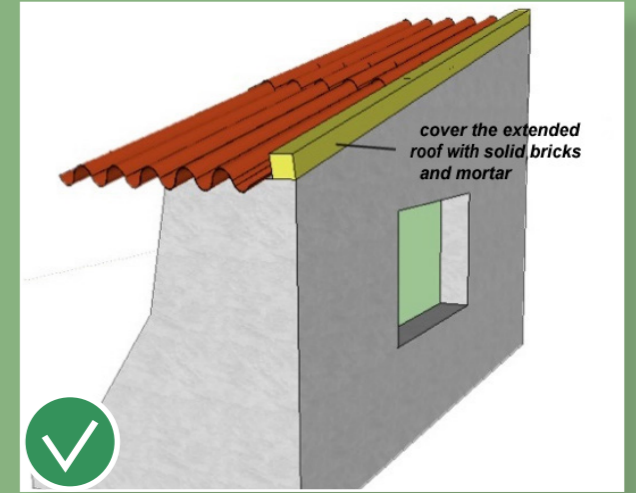
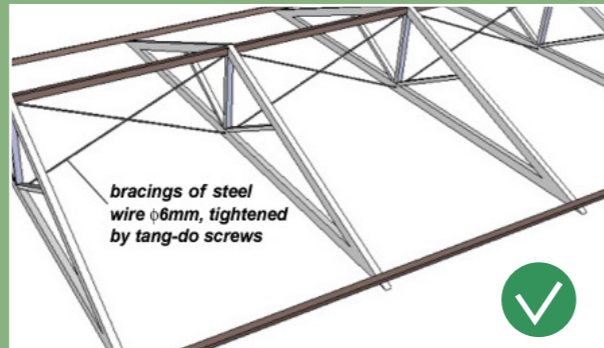
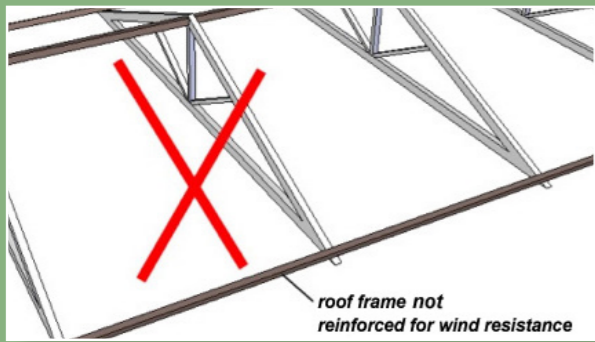
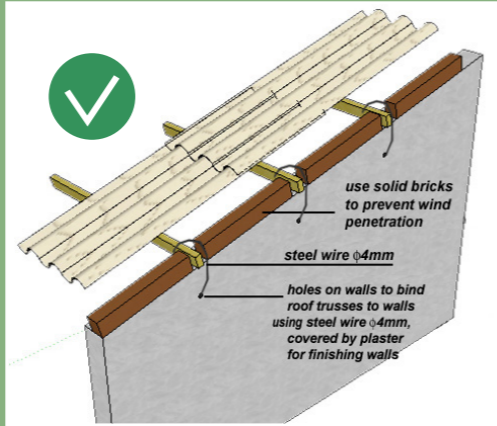
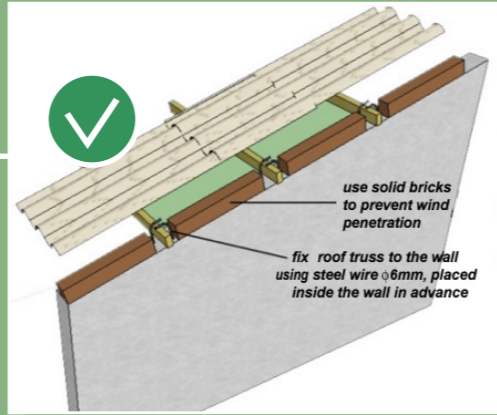
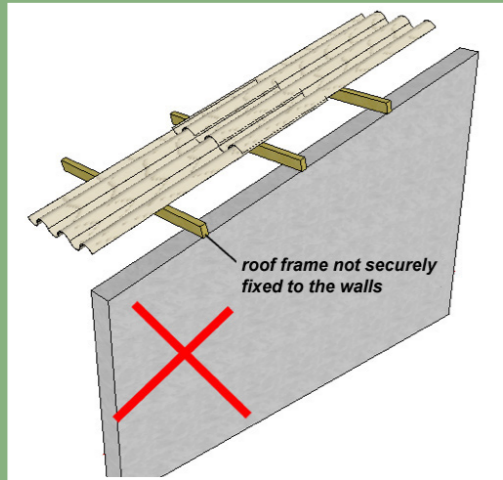

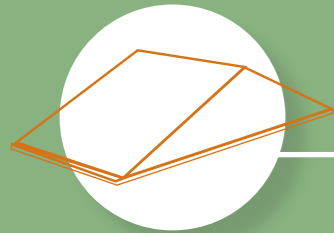

# ROOF

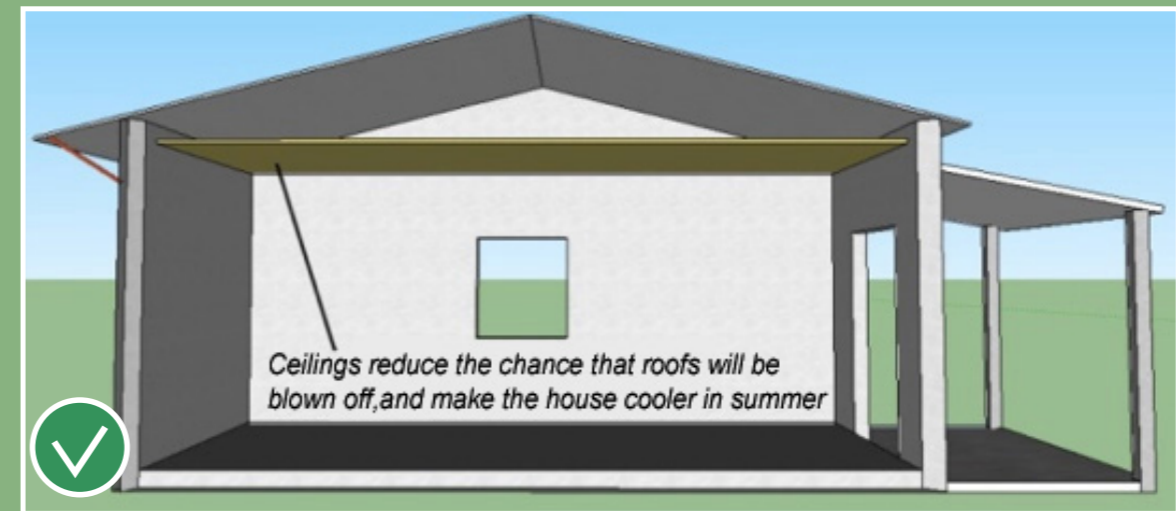
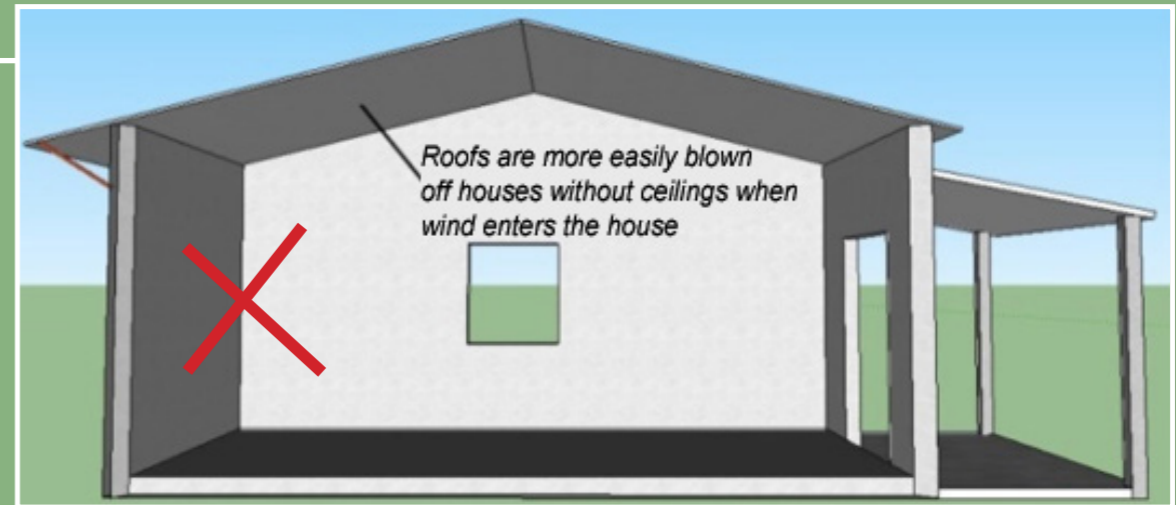
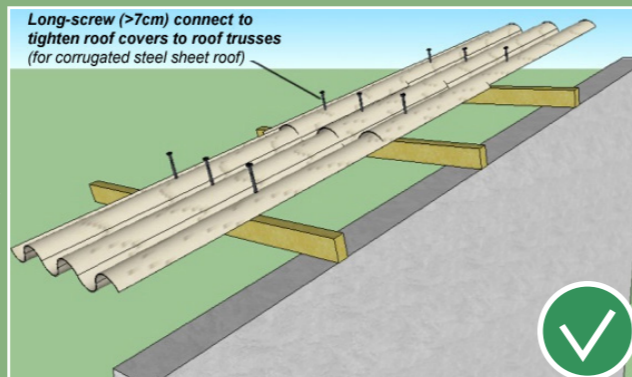
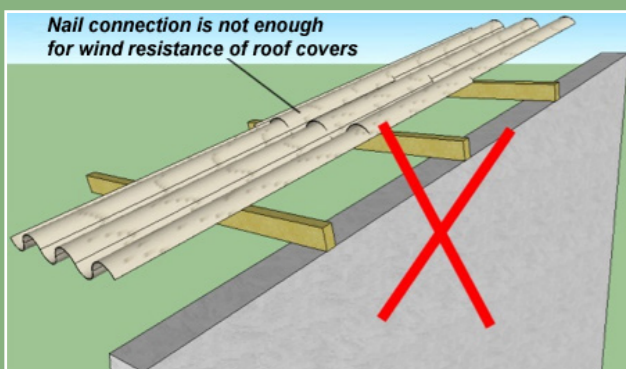
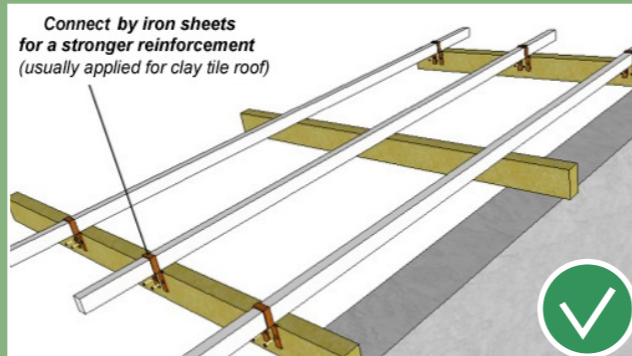
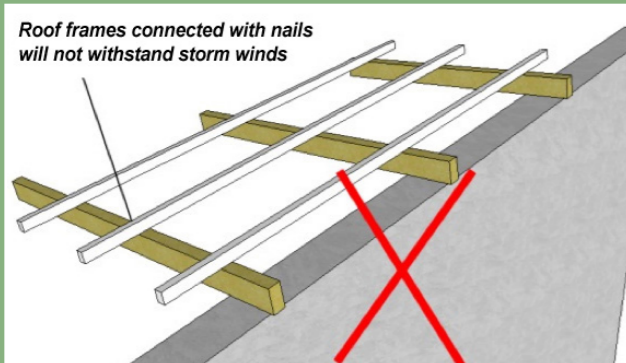

# DOORS AND WINDOWS

## DOORS AND WINDOWS INSTALLATION

- Tightly connect doors and windows using bolts, latches and strengthening bars in preparation for windstorms.
- Stick adhesive tape on glass window panes to strengthen the wind-resistance of the glass.
- Close openings between walls and roof, ventilation holes on gable sides, and on tops of doors and windows to avoid wind penetration.

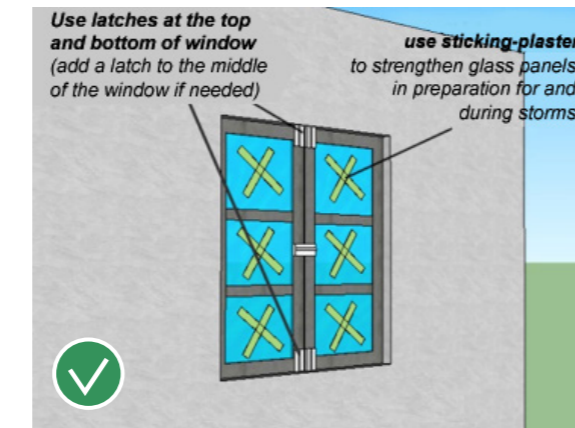
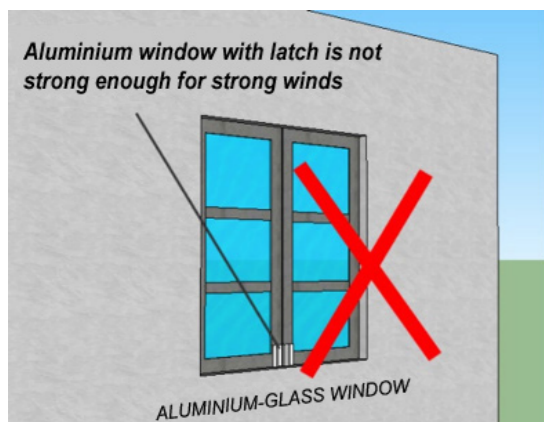
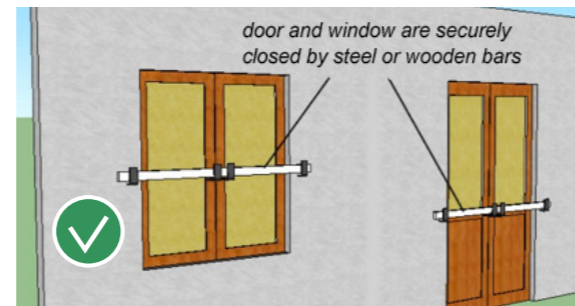
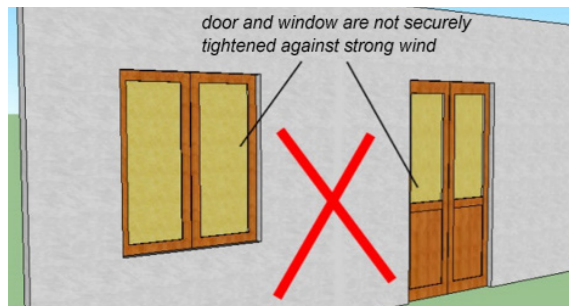

## DESIGN OPTIONS FOR TYPHOON-RESILIENT HOUSING

### NOTES:

People can choose one of these options if it suits the shape of the land, and the needs and economic conditions of the family. The guidelines for typhoon resilience provided in the previous sections of the document, however, should be guaranteed and followed to have a safe home.

1A



PERSPECTIVE

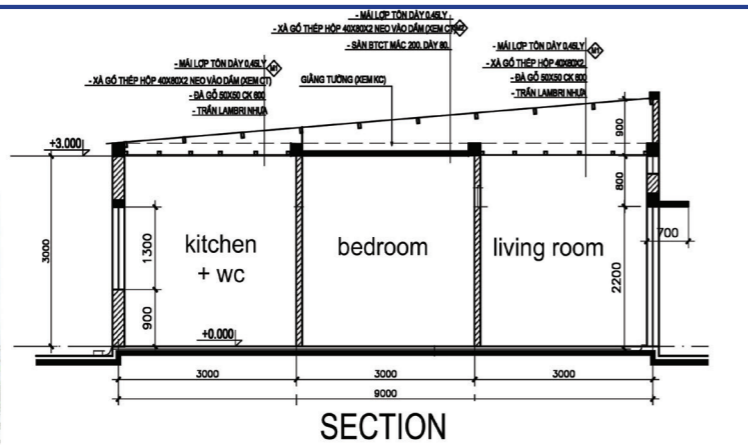

SECTION

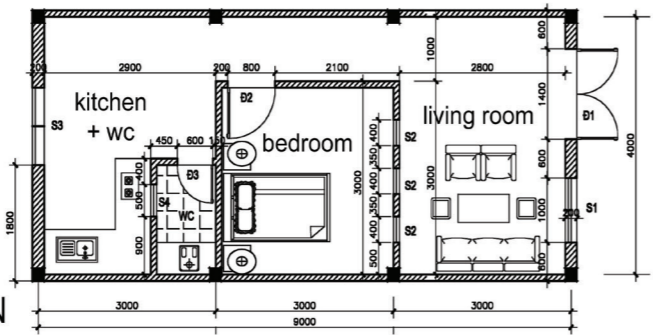

FLOOR PLAN

1B



PERSPECTIVE

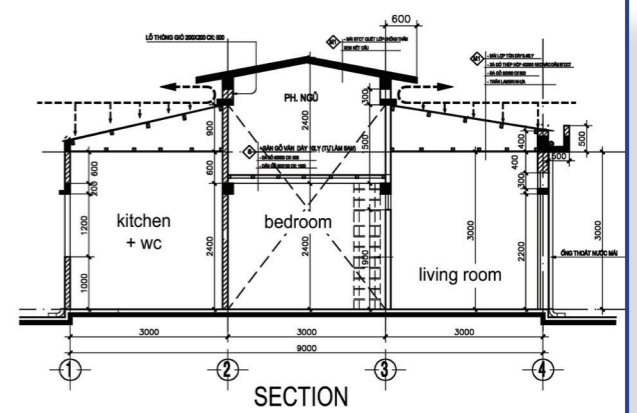

SECTION

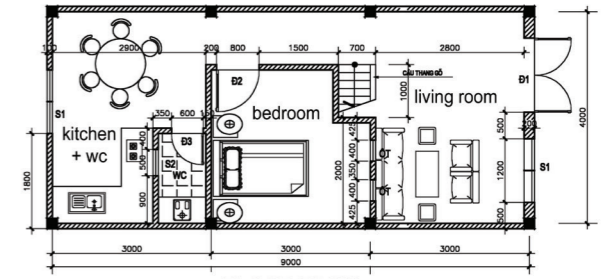

FLOOR PLAN

1

Source:  
Da Nang Department of Construction (DoC)

2A

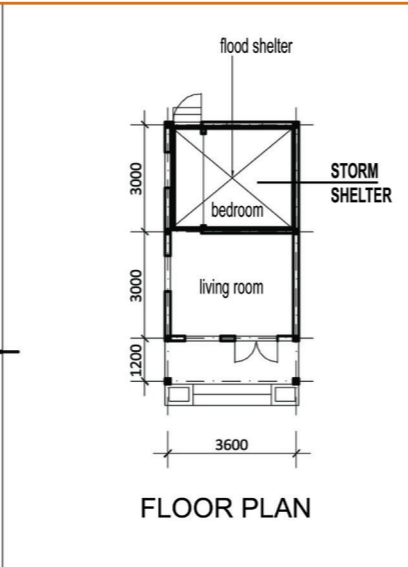
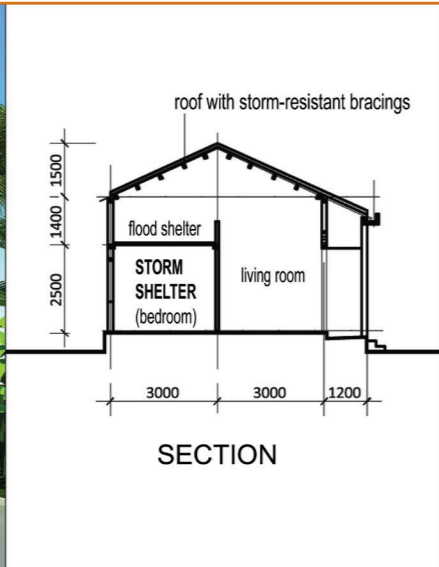

2C



2

Source:  
 Development Workshop  
 France (DWF), 2015. ATLAS:  
 House Design Collection.  
 Decision No.48/2014/  
 QD-TTg: Support the poor  
 in having typhoon- and  
 flood-resistant homes in  
 Central Viet Nam.

2B

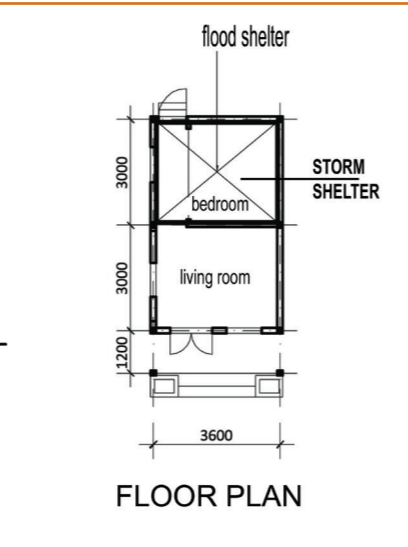
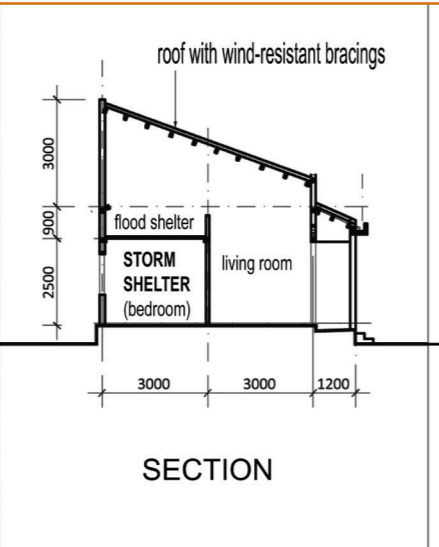

2D

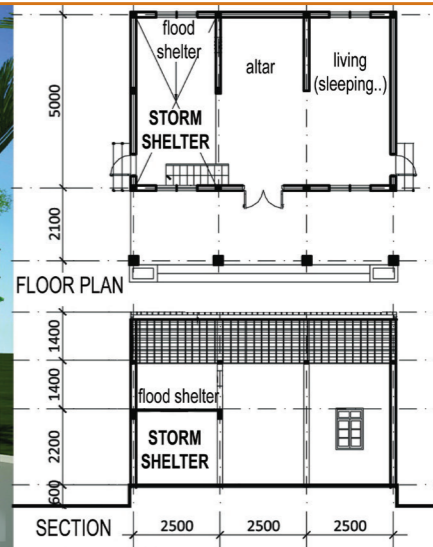
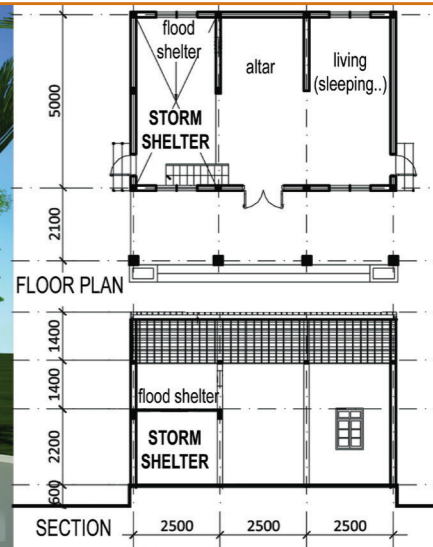

3A

PERSPECTIVE

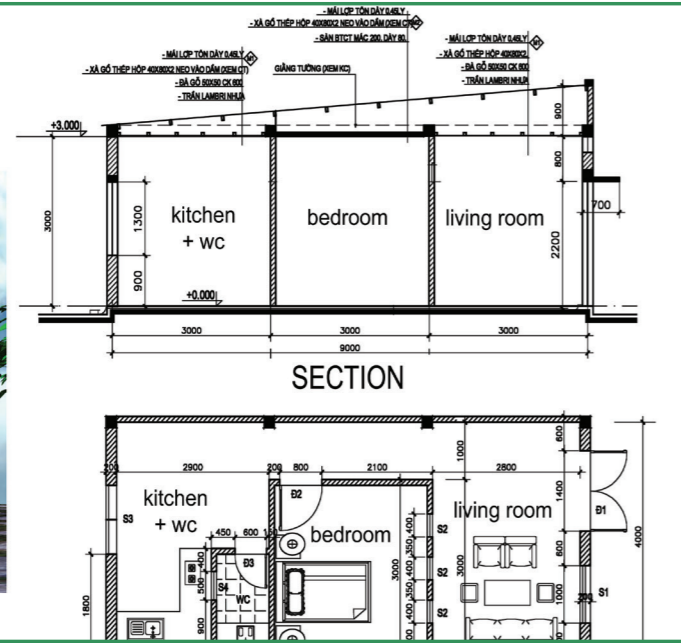

PERSPECTIVE

3B

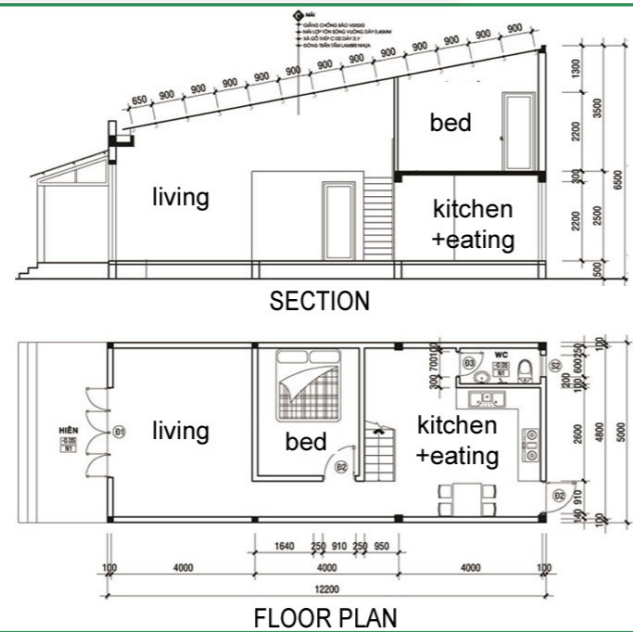

3C

PERSPECTIVE

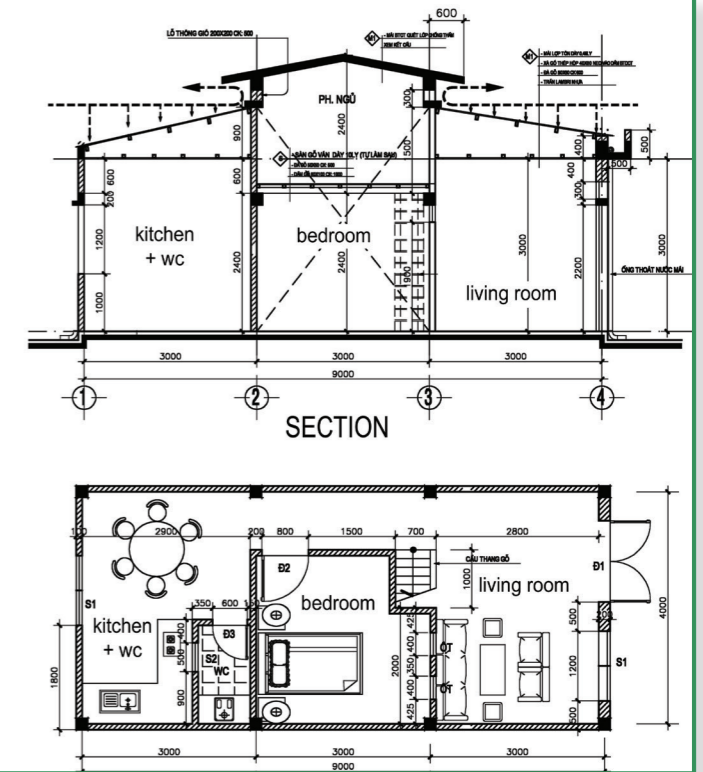

3

Source:  
Developed by the project research team based  
on field work and stakeholder consultation.

3D



PERSPECTIVE

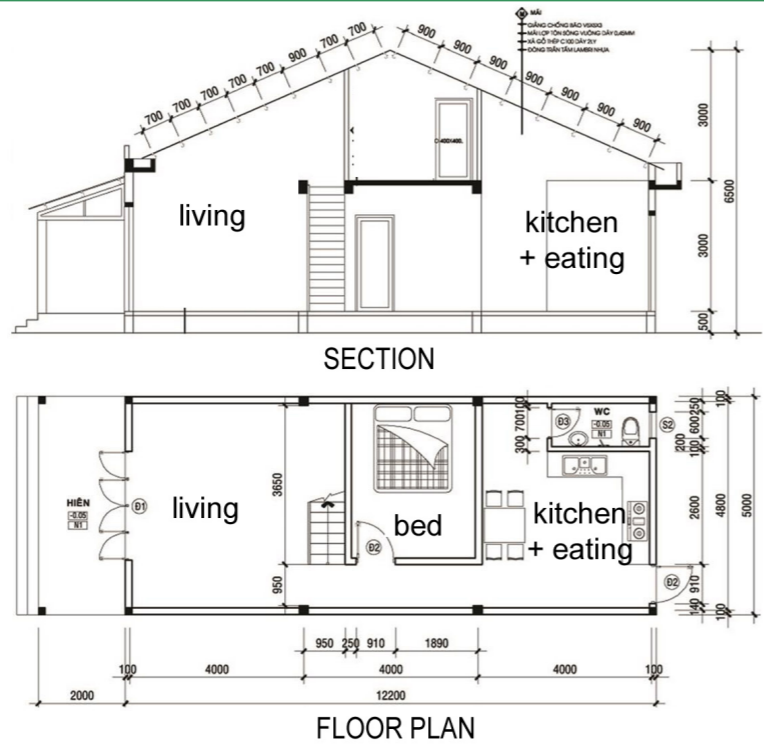

3E



PERSPECTIVE

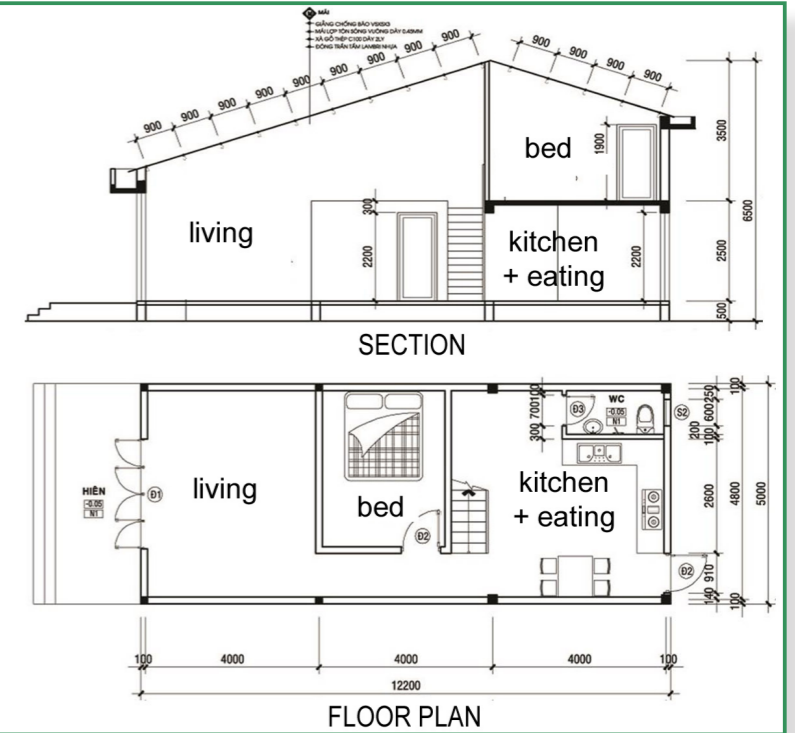

3

Source:  
Developed by the project research team based  
on field work and stakeholder consultation.



## FOR LOCAL BUILDERS

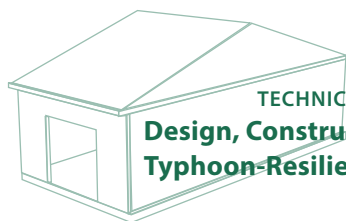

TECHNICAL HANDBOOK ON  
**Design, Construction and Renovation of  
Typhoon-Resilient Low-Income Housing**

Partners:



Canada



## CONTACT INFORMATION

Da Nang Department of Foreign Affairs

Ms. Đỗ Phương Thảo (Deputy Head of International Cooperation Unit): [thaodp7@danang.gov.vn](mailto:thaodp7@danang.gov.vn)

Ms. Ngô Viết Hoài Thương (Specialist): [thuongnvh@danang.gov.vn](mailto:thuongnvh@danang.gov.vn)

**Institute for Social and Environmental Transition-International (ISET-International)**

Mr. Trần Văn Giải Phóng (Technical Lead): [phongtran@i-s-e-t.org](mailto:phongtran@i-s-e-t.org)

Mr. Trần Tuấn Anh (Technical Staff): [tuan.anh@i-s-e-t.org](mailto:tuan.anh@i-s-e-t.org)